

Monitoring Power Quality System Based on Wireless Sensor Network Using VB6

Muthanna Ali Saihood , K. Lakshmi Bhavani , S Nagakishore Bhavanam

Abstract— The question of power quality has been widely discussed due to the increase of electrical loads in industrial facilities and in service and residential sectors, which has led to an increase in the load sensitivity to power disturbances. The objective of this paper goes beyond concepts and definitions to describe the basic philosophy of a system created to monitor electrical power quality, perform a true inspection of the power system, and assist utilities in making decisions related to cost reduction and easily solving power quality problems through clear indication of power load . It is interesting to note the degree of importance given to certain events in the electrical system. Obviously, the more serious the disturbance, the greater the interest is in analyzing and detecting the causes This paper discusses a new concept in power quality monitoring through the use of digital millimeters specially designed for use in circuits with nonlinear loads, together with other intelligent electronic devices. These devices allow utilities to monitor and analyze relevant disturbances in the distribution system. Interconnected equipment on a high-speed communications network provides the basis for an electrical power quality monitoring system. This system is a powerful tool for evaluating and minimizing the costs of interruptions, maintenance, and any other influencing factors that may negatively impact the power system. To implement these type of system for monitoring the transformers globally the transformer data like power quality, temperature, current parameters are taking using sensors and controllers and uploaded to server dynamically using WSN . The powerful device that use in this system is ZigBee.

Index Terms—WSN , ZigBee , Power Quality , Transformers, VB6 ,Temp sensors , Microcontroller.

1 INTRODUCTION

THE monitoring system of power transformers has many goals, important of them are Power management system Rationalize consumption the electrical power because know increasing the electrical load in particular region more than the transformers capacity can give order to decrease the load to rating value and saving the power in addition to that this system consider as protection for the transformers to avoid the damage of the transformers . The protection includes three objects over load , high core temperature and unbalance load. The monitoring of transformers status that located in the cities and villages can avoid damage due to high temperature of the transformer core , Temperature increasing to high level because over load or decreasing the oil level in the tank that using for cooling the transformers frame , Figure-1 show the transformer firing and its expose to damage .To alleviate the problems, in this paper we present a communication infrastructure to provide low cost, reliable data delivery.

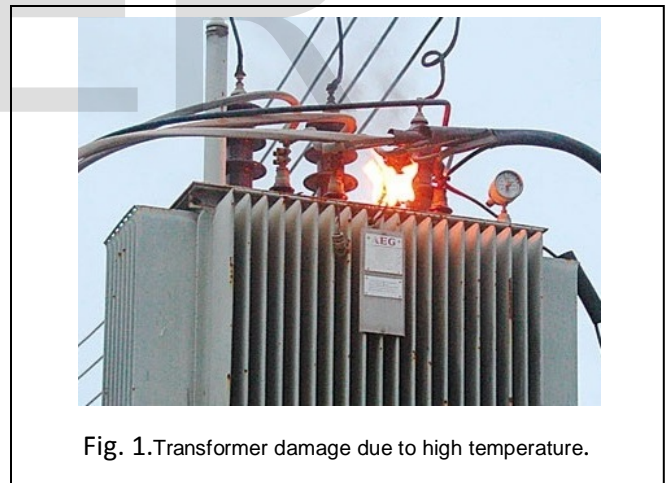

Fig. 1. Transformer damage due to high temperature.

reduce the proportion of losses in electrical transformers to 99.9% When use a good control and follow-up system. There are many distributed electrical transformers in the city streets so the manual monitoring system to be very difficult and it is not accurate because it is mainly based on human observation that there are often mistakes which are called human errors and not able to predict to the transformers status. When use electronic wireless monitoring system can know the status for all electrical transformers that distributed in the alleys and streets of

- Muthanna Ali Saihood is currently pursuing masters degree program in electronic and communication engineering , Acharya Nagarjuna University, Guntur, Andhra Pradesh , India.
E-mail: muthanna.alisaihood@gmail.com
- K. Lakshmi Bhavani is currently working as an Asst Professor in department of electronic and communication engineering, Acharya Nagarjuna University, Guntur, Andhra Pradesh , India.
E-mail: konduribhavani@gmail.com
- S Nagakishore Bhavanam is currently working as Asst Professor in department of electronic and communication engineering, Acharya Nagarjuna University, Guntur, Andhra Pradesh , India.
E-mail: kishore.ece.anu@gmail.com

cities with minimal effort and cost, The proposed system is characterized with high accuracy, and also can archive all the data for each electrical transformers by using data base server. when occur some problem to any transformer can know that directly by given alarm signal in the personal computer that located in base station or central office and can given order to operator persons to do repair and remove the problem before the electrical transformer damage. In general the power grids consist of the main three parts generation, transmission and distribution of electric power. Figure-2 shows an example of the configuration of a power grid. The electrical distribution system delivers electric power through feeders and pole transformers from distribution substations to end users such as houses, office buildings, and factories.

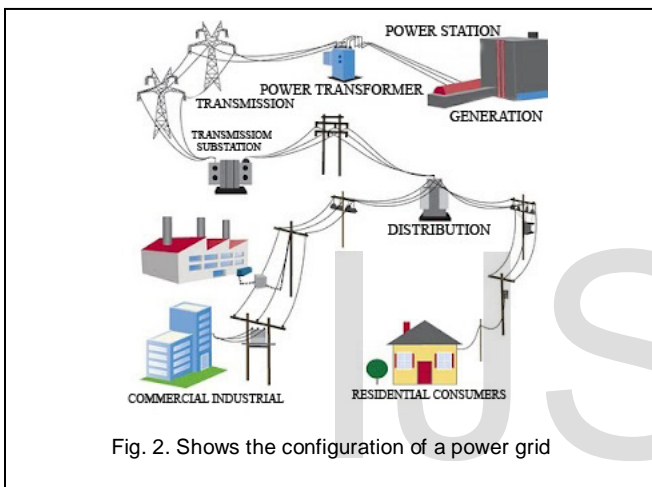

Fig. 2. Shows the configuration of a power grid

2 THE PROPOSED SYSTEM

The proposed system include design a reliable wireless sensor network WSN for a power quality monitoring system to provide high data delivery quality with the least cost of communication system installation and maintenance. This system take the information from pole transformers and send them to the base station. The speed of data that transmitted from the pole transformers to the base station 10 times per second that mean the update of information can occur ten times every one second. The information include the phase load, total load for three phase and core temperature for each pole transformer. The more efficient tools that use for this purpose is Zigbee as shown in Figure-3. ZigBee is an IEEE 802.15.4-based specification for a suite of high-level communication protocols used to create personal area networks. The technology defined by the ZigBee specification is intended line-of-sight, depending on power output and environmental characteristics.[1] ZigBee devices can

transmit data over long distances by passing data through a mesh network of intermediate devices to reach more distant ones. ZigBee is typically used in low data rate applications that require long battery life and secure networking (ZigBee networks are secured by 128 bit symmetric encryption keys.) ZigBee has a defined rate of 250 kbit/s, best suited for intermittent data transmissions from a sensor or input device. to be simpler and less expensive than other wireless personal area networks (WPANs), such as Bluetooth or Wi-Fi. Applications include wireless light switches, electrical meters with in-home-displays, traffic management systems.

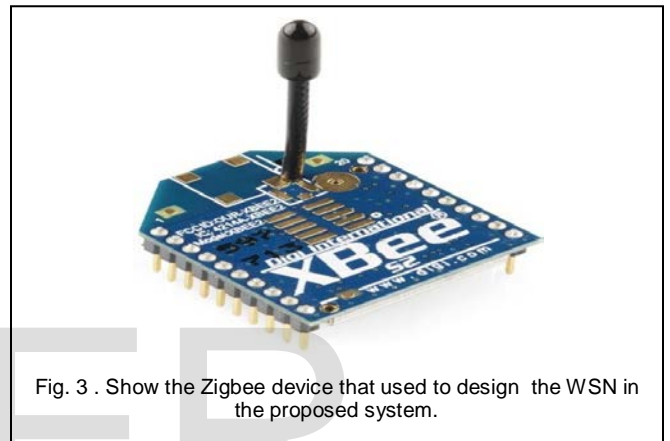

Fig. 3 . Show the Zigbee device that used to design the WSN in the proposed system.

The features of this device are:

- low power consumption.
- high density of nodes per network.
- Simple protocol , global implementation.
- Network flexibility.
- Small size less than 9mm x 9mm.
- Using in monitoring and control systems.

The microcontroller that will use in the proposed system is ARM7, Then connect the all pole transformers that distributed in the city as wireless network and collocated all the information in one place that called base station to monitor and archiving the information for each transformer . This system is powerful tools for power management system PMS. Its task is to make sure that the electrical system is safe and efficient. If the power consumption is larger than the power production capacity, load shedding is used to avoid blackout. power management systems to improve the reliability of the electrical distribution system while also increasing the financial and operational efficiency of enterprise then ensure that the electrical distribution system works seamlessly from utility service entrance to plug .The block diagram for the proposed system as shown in Figure-4.

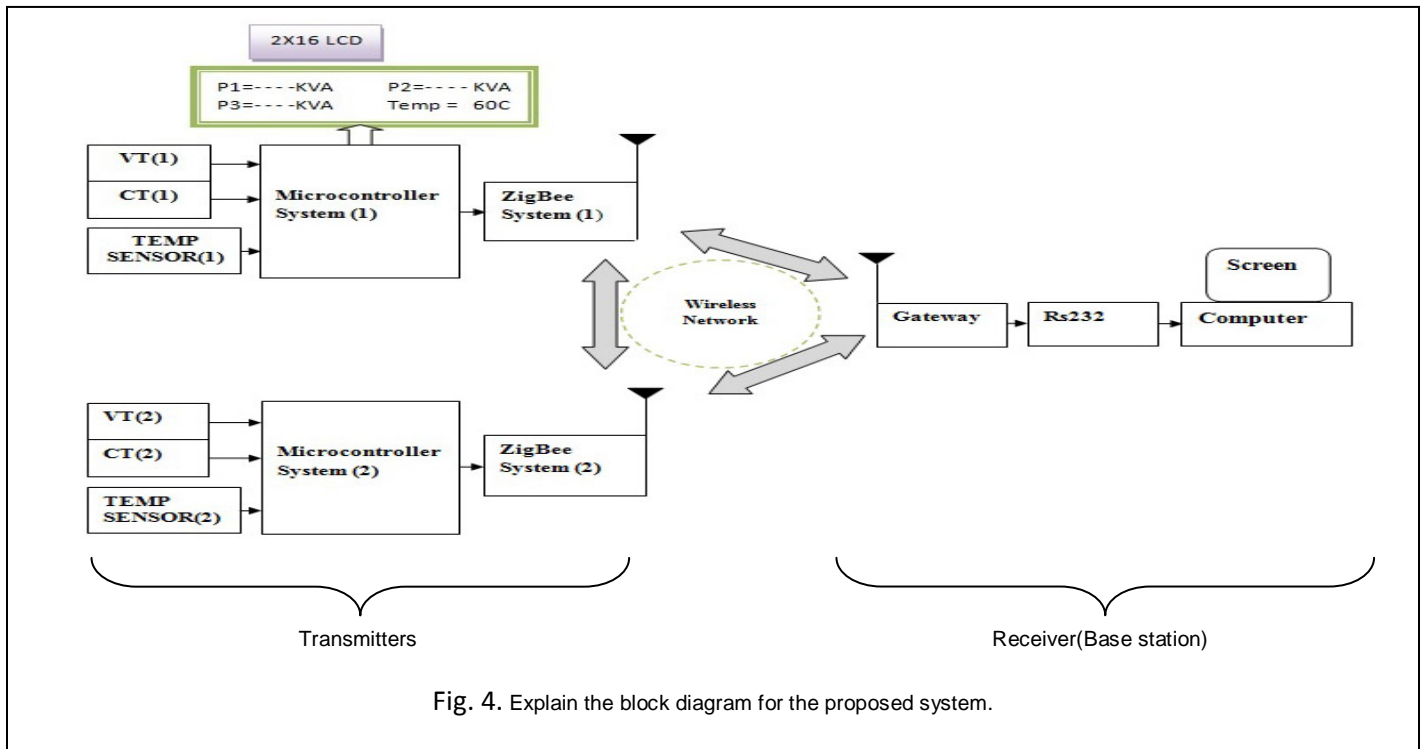

Fig. 4. Explain the block diagram for the proposed system.

The transmitter sensors are represented by three stages first stage current transformer CT and voltage transformer VT, The connection of CT and VT as shown in the Figure-5.

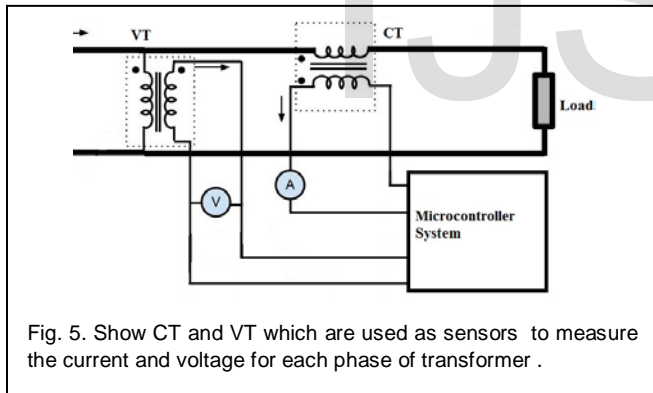

Fig. 5. Show CT and VT which are used as sensors to measure the current and voltage for each phase of transformer .

Then can compute the power for each phase by using electronic circuit buffer to convert the quantity of the current and voltage to signals that matching with microcontroller circuit . The temperature of core measured by using metal temperature sensors as shown in Figure-6, these sensors can measure high temperatures range with least error ratio.

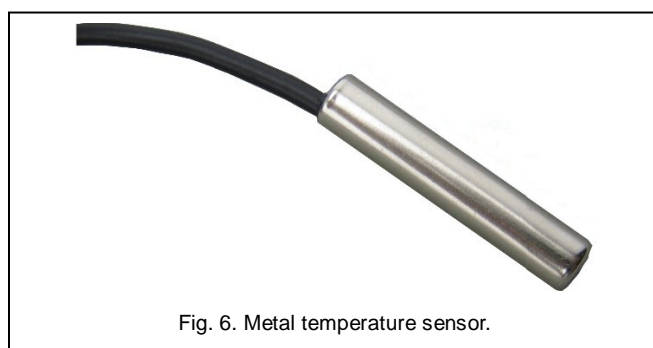

Fig. 6. Metal temperature sensor.

The metal temperature sensor are used to measure the core temperature of transformer . the microcontroller circuit receive all the information for each transformer voltage , current , and core temperature , the Zigbee device used as wireless sensor network to transmit the data to base station.

3 RUSULTS

The receiver circuit consist of gate way to collected all the transformers data from wireless network sensors and by using Rs232 protocol interfacing with personal computer to display all the information and monitoring them by operator persons . the software program is designed by Microsoft visual basic version 6 , This program display the information for each transformer , information includes the power in KVA for each phase , total load of each transformer and core temperature in Celsius unit . The ID of transformers is formatted with special way to include identification data , serial number, technical specifications , and located address of the transformer . this information can be formatted and enter them to computer through the program for each transformer and save it in data base server by double click on the text that allocated to that purpose then appear box as shown in Figure-7 and write the ID for particular transformer then press ok command to save it in data base , this procedure can do it for all transformers ID that located in the area of wireless network design.



Fig. 7. Text box to fill the ID of the transformers.

Figure-8 represent the load for each phase in KVA unit , total load and core temperature in Celsius unit of the transformer , These information are received directly from the transformer location by wireless sensor network technique and updated ten times per second .

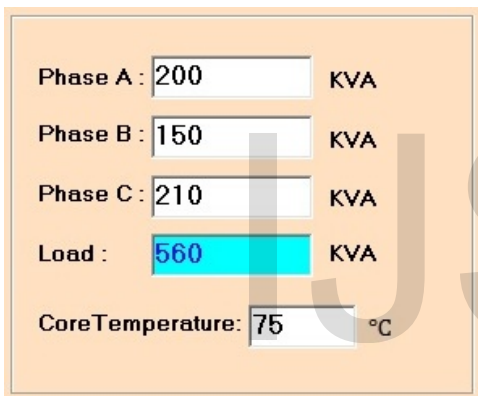

Fig. 8. show the load for each phase , total load and core temperature of the transformer.

Figure-9 explain the setting for each quantity temperature, overload and unbalance . when set value for each one these consider the threshold levels to give the alarm signals , when the actual reading greater or equal than the set value then the alarm signal flashing will appear with different colors depending on difference value rate between setting value and actual value. The proposed system help operators by observing the appearance of alert signals .The setting signals includes three items temperature setting , overload setting and unbalance setting , by press the two blue button can increase or decrease the setting value as shown in Figure-9.

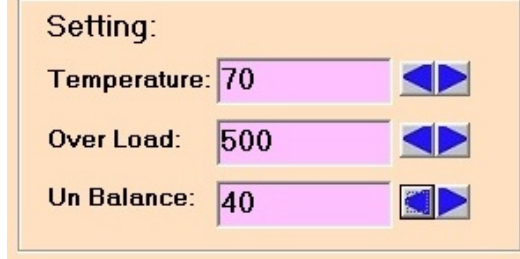

Fig.9. Explain the setting for each quantity temperature, overload and unbalance phases.

The alarm signals block as shown in the Figure-10 illustrates three alarm signals for each transformer, the unbalance signal is load difference between each two phase load for three phases of one transformer for ideal operation there are no difference between phases load of transformer that mean the difference equal to zero ,If there are high difference the transformer is in bad operation then the system gives alarm signal, the alarm signals colors are change depending on difference value rate between setting

TABLE1

EXPLAIN THE ALARM SIGNALS COLORS

No	Difference value	Alarm signal colors
1	LOW	GREEN
2	MID	YELLOW
3	HIGH	RED

value and actual value as shown in the table-1.If the difference is low the alarm signal color is green and converted to yellow color if the difference value is mid and if the difference value is very high the alarm signal color change to red color to explain the operation in dangerous level , The operator person can monitor these signals easily if one is appear then can do the repair for particular transformer the alarm signals will disappear and cancel automatically by system.



Fig. 10. Explain the alarm signals(High Temp, Over load and UnBalance)

The software for the system is explain in Figure-11 including all the transformers information , and can add more transformers if the system is extension the right side explain 32 transformers in the network T1,T2,.....,T32 color for each one refer to more dangerous alarm signal that appear in transformer, if the transformer status is normal

the color change to gray. The important feature for the proposed system is archiving all the information in data base server and can searching by date and time which the information that occurred and display the old information that occurred in previous date.

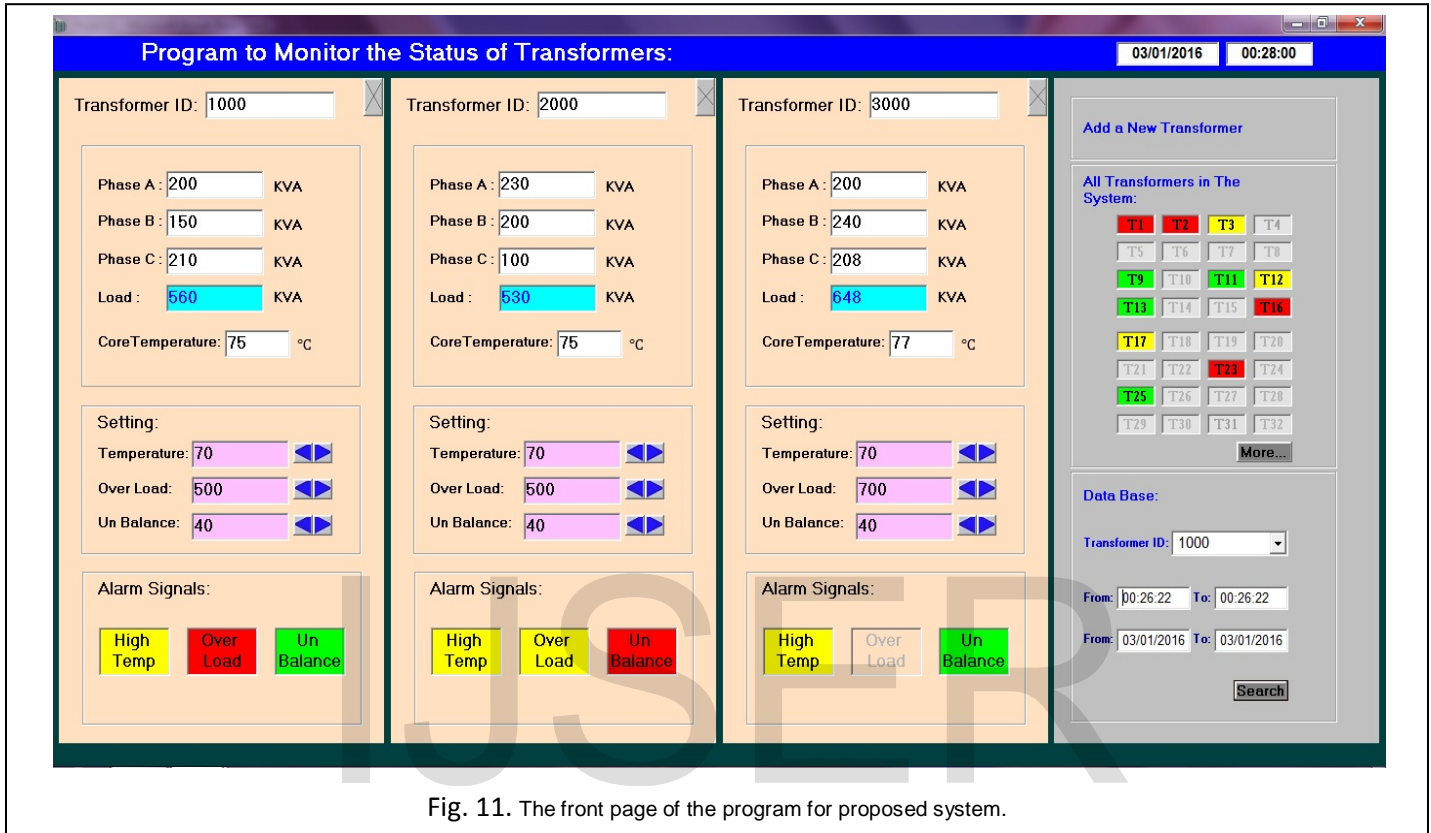

Fig. 11. The front page of the program for proposed system.

4 CONCLUSION AND FUTURE SCOPE

This paper is proposed system to design and implementation the wireless sensor network instead of the GSM system which send one message every half an hour so consider costly and useless in other applications but the proposed system can send ten message per one second . This system use to monitor the power quality of the pole transformers and monitor each transformer details phases load and core temperature . It consider powerful tools useful in power management system due to collect all the load of pole transformers in one system through which can know low and high load consumption region . In future work can add control system in addition to currently monitoring system and can switch off a pole transformer when the load increasing above the rating value .In addition to that the changes in the power system load affects mainly on the system frequency then can design control system able to provide the acceptable levels of power quality and keeping the frequency and voltage

magnitude within tolerable limits by using PID or fuzzy controller.

5 REFERENCES

- [1] Intanagonwivat, C.; Govindan, R.; Estrin, D. Directed diffusion: A scalable and robust communication paradigm for sensor networks. In Proceedings of ACM International Conference on Mobile Computing and Networking, Boston, MA, USA, 6-11 August 2000; ACM Press: New York, NY, USA, 2000; pp. 56-67.
- [2] Handy, M.J.; Haase, M.; Timmermann, D. Low energy adaptive clustering hierarchy with deterministic cluster-head selection. In Proceedings of IEEE International Conference on Mobile Wireless Communications and Networks, Stockholm, Sweden, 9-11 September 2002; pp. 368-372.
- [3] Krap, B.; Kung, H.T. GPSR: Greedy Perimeter Stateless Routing for wireless networks. In Proceedings of ACM International Conference on Mobile Computing and Networking, Boston, MA, USA, 6-11 August 2000; ACM Press: New York, NY, USA, 2000; pp. 243-254.

[4] Hou, Y.T.; Shi, Y.; Sherali, H.D.; Midkiff, S.F. On energy provisioning and relay node placement for wireless sensor networks. *IEEE Trans. Wirel. Commun.* 2005, 4, 2579-2590.

IJSER